

**PRODUCT DATA SHEET**

Product Information			Customer Information	
Description: Double Angle Cutter			Company Name:	
Raw Material:			Address:	
Application:			Contact Person:	
Machine:	Speed(rpm):	Feed(mm/min):	Tel:	
	Cutting Speed(m/min):	Feed(mm/rev):	Tfx:	
Coolant flow:	Coolant pressure:		e-Mail:	
Type of Coating (Select from below)	Coating	Non-coating	Skype:	
TialN    AlTiN    AlCrN    TiN    TiCN    DLC    Diamond			Enquiry	Order
			Quantity:	

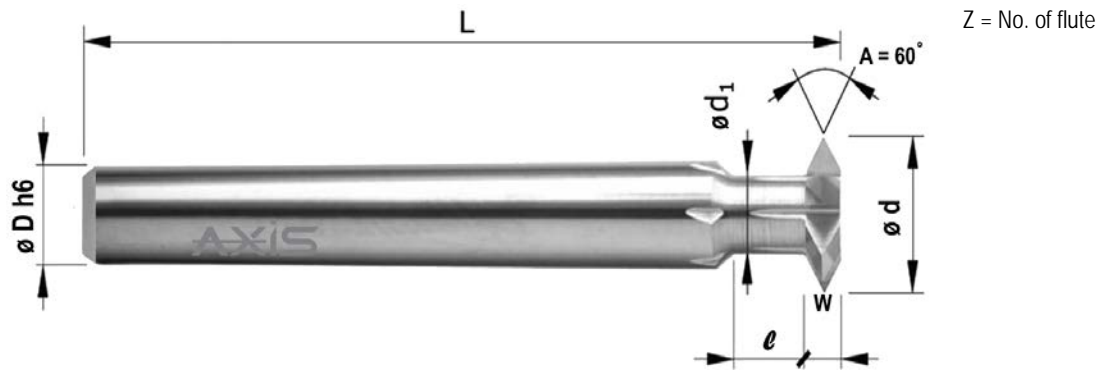

Helix ( $\lambda$ ) = 0

$d < D \rightarrow d \pm 0.010$

$d1 : +0.0 / -0.500$

Rake ( $\gamma$ ) = 6 - 15

$d = D \rightarrow d -0.050 / -0.100$

$l : \pm 0.2$

Parameters for tool:

d	
d1	
l	
L	
D	
W	
Z	

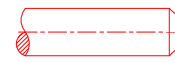

Form HA



Form HAK



Form HB

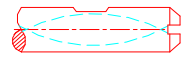

Form HBK



Form HE



Form HEK

Right Hand    Left Hand

**DIRECTION**

- All Dimensions in mm otherwise specified.